



QUICK START GUIDE

2025

LARGE TULIP WIND TURBINE





Table of Contents

Introduction & Recommendations.....	2
Safety Warnings.....	10
Parts Breakdown.....	11
Tools & Hardware.....	11
Substructure Preparation.....	12
Mounting Turbines to the Base.....	12
Connecting Electrical Components.....	13
Maintenance.....	14
Troubleshooting.....	14
Liability Disclaimer.....	17
Warranty Information.....	17
Frequently Asked Questions.....	18
Contact Information.....	18
Appendix.....	20





Introduction & Recommendations

Thank you for purchasing our products. This guide will highlight some basic and important information. For more detailed information about wind energy, please see the resources at www.flowerturbines.com

The Large Tulip (5 m high blade) turbine will provide excellent amounts of power at normal wind speeds and are a good choice for combining utility and style. Most of the time, you will want to connect it to the grid to reduce your home or business electric bill. Each turbine has the potential for up to 5,000 watts in smaller groups. Depending on your wind speed, we may want to make these 7,500 or 10,000 watt electronics in groups of 10 or more. Our salespeople will try to find the solution that works for you.

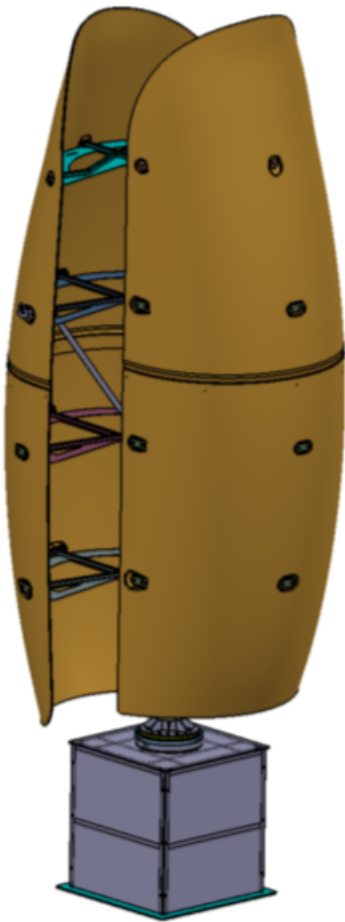

Total Weight: 798.5kg (1760.4 pounds)

Base Area (Turbine stands on base plate and fastened with bolts): 0.643 m² (6.9212 square feet)

Mounting Nuts Area (Turbine's base mounted on threaded rods with nuts): 0.0075 m² (0.0807 square feet)



Pressure (Turbine stands on base plate): 12418.35 N/m² (259.36 lb/ft²)

Pressure (Turbine mounted with threaded rods): 1064666.7 N/m² (22236.03 lb/ft²)

In general, they can be placed on many commercial flat roofs, but it is your responsibility to check on this with your engineer.

For information on the base, see the appendix

They can also be off-grid and provide power for lighting, charging, etc.

The arrangement may be on or off the grid.

In both cases, they will usually have a charge controller that connects the turbine generator to a battery, and, for a grid connection, an on-grid inverter. In our EU-compatible models, our smaller installations allow for grid connection without a battery, as some of our inverters are produced with charge controllers included.

The electricity generated usually is arranged as follows:

1. The turbine shaft is connected to a permanent magnet generator of 24 or 48 volts that produces AC power that needs to be adjusted for use.
2. The next step for the electricity is to pass through a charge controller which rectifies the AC to usable DC power.
3. The DC power from the charge controller then either goes to a battery, usually 12, 24, or 48 volts, which is often a source for off-grid power, or to a battery/inverter combination or inverter alone that goes to the grid. As mentioned, in the EU for some projects, the controller is built into the inverter. In all cases, the specifics will depend on your project (parameters like size of the turbines, wind speed, number of turbines in the project, etc.), and we may give you a custom solution using the elements above or similar ones. For many small on-grid projects in countries with US-type voltage, the on-grid inverter will be connected to a 48 volt battery.

You may choose the battery you want to go with the system.

You may choose to have us buy it for you or buy it yourself. We sometimes recommend you purchase it yourself, as batteries may be difficult to transport.

When you choose a battery, it needs to have voltage compatible with the system we make for you. Our staff will help you with that. You will need to decide how much back-up power you want your battery to have. Most batteries will be sold by “ampere hours”. You can multiply that number by the battery voltage to get the number of watts. Let us say that you find a battery with



1000 watts. If you decide that you want to have storage available to power a 10 watt light bulb, this battery will do so for 100 hours. This calculation is approximate, and, if you want emergency backup, you should buy somewhat more than the amount you think you will need.

Output per Large Tulip turbine in various numbers

Below are power curves/tables for the expected power of each turbine when appropriately placed in a group of 3, 5, or 10. Your sales representative will help you understand how to place them in groups. A power curve is a table or plot of wind speed versus expected power. Your actual results can be higher if you have strong gusts and lower, depending on the electronics used for the project.

The following tables provide an overview of the power output generated by a single Small Tulip turbine up through groups of 3 through 9. It demonstrates how wind speed, measured in meters per second and miles per hour, influences the turbine's energy production, expressed in watts.

Efficiency rises the more turbines grouped in a bouquet.

Use these tables to estimate the energy output based on wind speeds in your area.

Table 1: Power Output of A Single Turbine by Wind Speed

(Watts produced by a each Large Tulip turbine, when alone, shown in meters per second and miles per hour)

Wind Speed (m/s)	Wind Speed (mph)	Power Output (Watts)
0.0	0.0	0.0
0.5	1.1	0.4
1.0	2.2	3.0
1.5	3.4	10.1
2.0	4.5	24.0
2.5	5.6	46.9
3.0	6.7	81.0
3.5	7.8	128.6
4.0	8.9	192.0
4.5	10.1	273.4
5.0	11.2	375.0



5.5	12.3	499.1
6.0	13.4	648.0
6.5	14.5	823.9
7.0	15.7	1,029.0
7.5	16.8	1,265.6
8.0	17.9	1,536.0
8.5	19.0	1,842.4
9.0	20.1	2,187.0
9.5	21.3	2,572.1
10.0	22.4	3,000.0
10.5	23.5	3,472.9
11.0	24.6	3,993.0
11.5	25.7	4,562.6
12.0	26.8	5,184.0
12.5	28.0	5,859.4
13.0	29.1	6,591.0
13.5	30.2	7,381.1
14.0	31.3	8,232.0
14.5	32.4	9,145.9
15.0	33.6	10,125.0

Table 2: Power Output of Each Turbine in a Bouquet of 3 Turbines by Wind Speed

(Watts produced by a each Large Tulip turbine, in a group of three turbines, shown in meters per second and miles per hour)

Wind Speed (m/s)	Wind Speed (mph)	Power Output (Watts)
0.0	0.0	0.0



0.5	1.1	0.7
1.0	2.2	5.3
1.5	3.4	17.7
2.0	4.5	42.0
2.5	5.6	82.0
3.0	6.7	141.8
3.5	7.8	225.1
4.0	8.9	336.0
4.5	10.1	478.4
5.0	11.2	656.3
5.5	12.3	873.5
6.0	13.4	1,134.0
6.5	14.5	1,441.8
7.0	15.7	1,800.8
7.5	16.8	2,214.8
8.0	17.9	2,688.0
8.5	19.0	3,224.2
9.0	20.1	3,827.3
9.5	21.3	4,501.2
10.0	22.4	5,250.0
10.5	23.5	6,077.5
11.0	24.6	6,987.8
11.5	25.7	7,984.6
12.0	26.8	9,072.0
12.5	28.0	10,253.9
13.0	29.1	11,534.3



13.5	30.2	12,917.0
14.0	31.3	14,406.0
14.5	32.4	16,005.3
15.0	33.6	17,718.8

Table 3: Power Output of Each Turbine in a Bouquet of 5 Turbines by Wind Speed
(Watts produced by each Large Tulip turbine, in a group of five turbines in meters per second and miles per hour)

Wind Speed (m/s)	Wind Speed (mph)	Power Output (Watts)
0.0	0.0	0.0
0.5	1.1	0.9
1.0	2.2	6.8
1.5	3.4	23.1
2.0	4.5	54.7
2.5	5.6	106.9
3.0	6.7	184.7
3.5	7.8	293.3
4.0	8.9	437.8
4.5	10.1	623.3
5.0	11.2	855.0
5.5	12.3	1,138.0
6.0	13.4	1,477.4
6.5	14.5	1,878.4
7.0	15.7	2,346.1
7.5	16.8	2,885.6
8.0	17.9	3,502.1



8.5	19.0	4,200.6
9.0	20.1	4,986.4
9.5	21.3	5,864.4
10.0	22.4	6,840.0
10.5	23.5	7,918.2
11.0	24.6	9,104.0
11.5	25.7	10,402.8
12.0	26.8	11,819.5
12.5	28.0	13,359.4
13.0	29.1	15,027.5
13.5	30.2	16,829.0
14.0	31.3	18,769.0
14.5	32.4	20,852.6
15.0	33.6	23,085.0

Table 4: Power Output of Each Turbine in a Bouquet of 10 Turbines by Wind Speed
 (Watts produced by each Large Tulip turbine, in a group of ten turbines in meters per second and miles per hour)

Wind Speed (m/s)	Wind Speed (mph)	Power Output (Watts)
0.0	0.0	0.0
0.5	1.1	1.7
1.0	2.2	13.5
1.5	3.4	45.6
2.0	4.5	108.0
2.5	5.6	210.9
3.0	6.7	364.5



3.5	7.8	578.8
4.0	8.9	864.0
4.5	10.1	1,230.2
5.0	11.2	1,687.5
5.5	12.3	2,246.1
6.0	13.4	2,916.0
6.5	14.5	3,707.4
7.0	15.7	4,630.5
7.5	16.8	5,695.3
8.0	17.9	6,912.0
8.5	19.0	8,290.7
9.0	20.1	9,841.5
9.5	21.3	11,574.6
10.0	22.4	13,500.0
10.5	23.5	15,627.9
11.0	24.6	17,968.5
11.5	25.7	20,531.8
12.0	26.8	23,328.0
12.5	28.0	26,367.2
13.0	29.1	29,659.5
13.5	30.2	33,215.1
14.0	31.3	37,044.0
14.5	32.4	41,156.4
15.0	33.6	45,562.5

As illustrated in the power curves, the energy output significantly increases with the number of turbines positioned in a bouquet as well as higher wind speeds. By leveraging the Bouquet



Effect™, turbines work together to enhance efficiency, delivering greater energy production than individual units. Proper placement and alignment are key to optimizing performance and maximizing the benefits of wind energy.

In all cases, you will have the greatest benefit by using more turbines to achieve a stronger Bouquet Effect™.

Safety Warnings

Although our turbines are made with safety in mind, a few precautions are necessary:

1. Prevent accessibility to children.
2. Packaging and small parts can cause choking, do not allow small children to have access to them.
3. The unit should be used in a protected area. If on the ground, each unit should be surrounded by a chain link fence (so wind can pass through) and secured with a lock.
4. Do not place your hand inside the turbine while it is in operation. If the turbine is spinning at low speeds, you can carefully slow it down manually by gently applying pressure with a thick, non-metallic object, such as a sturdy rubber or wooden tool. This minimizes the risk of injury and protects the turbine components. Never use a metal object or excessive force to stop the turbine.
5. Do not run your fingers along any of the blade or metal edges, since they may still have sharp areas.
6. Depending on the project, a certified electrician and/or contractor should do installation work.
7. Hire a licensed/bonded installer for roof mounting.
8. Hire a licensed contractor or sub-contractor to pour and install concrete/foundational mounting.
9. Consult local regulations and ensure compliance with all local building codes and grid connection regulations.
10. Keep the products stored in a dry environment at room temperature up to the date of installation.



Parts Breakdown

1. Turbine (top)

This consists of a generator which attaches to the turbine shaft above and an adapter below to enable the generator to connect to it from a fixed location on a stationary structure.

2. Blades (of turbine)

Each blade comes in two sections each, a lower and upper.

3. Base (bottom)

This is made of strong steel and has places to connect to the ground. The ideal is drilling into concrete. Rooftop installations can usually be made into concrete or steel frames on the roof.

4. Electrical components

a. Generator

This permanent magnet generator is rated at 100 watts but can generate up to 200 watts for short periods. The charge controller limits the output to about 100 watts. It connects to the turbine shaft.

b. Charge Controller

Our custom-designed charge controller consumes minimal background electricity, reducing battery drain when not in use. It has:

- A light indicating charging status.
- A switch to stop the turbine.

c. Battery (Optional)

d. Inverter

5. Brake (electronic and/or mechanical)

The Large Tulip turbines have an electronic brake and a simple mechanical brake. There is also programming in the control system to brake at certain wind speeds automatically.

Tools & Hardware

1. Tools (not provided)

A variety of wrenches will be needed, depending on the product.

- 16mm socket wrench
- 6mm, 8mm, or 10mm Allen wrench
- Crane may be needed

2. Hardware (provided):

- Large Tulip Turbine (in 2 pieces)
- Base



Substructure Preparation

1. Fencing

We recommend a chain link fence so wind can pass through.

2. Foundation

Determining the foundation specifications is the job of your local civil engineer. We have made some calculations to be helpful. A larger base saves concrete and is lower. If you want to place the turbine high, you need a lot more concrete.

Some concrete dimension examples for the Large Flower Turbine, calculated for steady wind at 35 m/s:

- a. Case 1: Broad foundation
 - i. Base: 2500 x 2500 mm, 900 mm high, 5.6 cubic meters
- b. Case 2: Low and long foundation (this keeps the 2750 mm for each turbine next to each other so that the turbines can be clustered aerodynamically, but gives a wider overall foundation in the other, non-clustered direction):
 - i. 2500x4000 mm, 500 mm high, 5 cubic meters.
 - ii. Note that less concrete is needed because the foundation is larger.
- c. Case 3: maximizing height within reason foundation:
 - i. 2 m height: 2100x2100 mm, height 2000 mm, 9 cubic meters
 - ii. 4 m height: 1900.1900 mm, height 4000 mm, 14 cubic meters
- d. Conclusion: Normal use is a foundation that is 2500x2500 mm.

3. Mounting Turbine to Base

Mounting Turbines to the Base

The base should be bolted firmly in concrete according to the following guidelines:
(This is calculated for steady wind at 35 m/s.)

Table 5: Variety of Bases for Large Tulip Turbines

(Dimensions and necessary concrete sizes for Large Tulip Turbines, depending on case)

Length (mm)	Width (mm)	Height (mm)	Concrete Volume (cubic meters)	Remarks
2500	2500	900	5.6	Broad base for steady wind at 35 m/s.
2500	4000	500	5	Low and long base, suitable for aerodynamic clustering; requires less concrete.



2100	2100	2000	9	Maximizing height (2m); more concrete needed for stability.
1900	1900	4000	14	Maximizing height (4m); significantly higher concrete requirement.

Conclusion: Standard base (1200 x 2500 mm) recommended for normal use; larger base saves concrete and is lower.

When on a roof, you need to consult with your civil engineer. The Eco-roof design (see our other brochure on this product for the 2-meter turbine) helps spread the weight over a greater area in case that is needed.

Connecting Electrical Components

This can vary depending on your system. A licensed electrician should be used. Installation must be conducted by a licensed and registered professional to ensure compliance with all local electrical codes and standards.

The generator will have three output wires. All three should be connected separately to the appropriate connection on the controller or inverter. It does not matter which wire attaches to which connecting pole on the controller or inverter. Some controllers may have multiple poles but label three for wind. Only those should be used. The solar panels will be grouped separately. For more connection based information, refer to your charge controller and battery operation manuals.

We recommend replacing the oil once every two years, more often in settings of average wind more than 7 meters per second, less often in winds below 5 meters per second. The bearings have nipples for ingress and egress of the oil.

Below is a table of some compatible bearing greases:



Table 6: Greases Compatible with Medium Tulip Turbines

BEARING	GREASE BRAND	GEAR
Aralub HLP2	ARAL	Aralub LFZ1
Rhus L 474/2	MOTUL/BECHEM	Berulit GA 400
Energrease LS - EP2	BP	Energol WRL/GR 154 GS
Grease LMX	CASTROL	
Beacon EP2	ESSO	Surret Fluid NX
Mobilux EP2	MOBIL	Mobilgear OGL 007
Retina EP2 - Alvania EPLF2	SHELL	Malléus GL 205
Multis EP2 - Lical EP2	TOTAL	Ceran AD+

Maintenance

1. General inspection and listen for noise. We recommend an annual check of your turbines.
2. Check for loose wires. Inspect all electrical connections, including those between the turbine, charge controller, and inverter, to ensure they are secure and properly connected. Look for signs of wear, corrosion, or damage in the wiring. If you find any loose or damaged wires, tighten the connections or replace the wires as needed to maintain optimal performance and safety.
3. We recommend greasing for adequate lubrication once every two years, more often in settings of average wind more than 7 meters per second, less often in winds below 5 meters per second.

Troubleshooting

This section addresses common issues you might encounter and provides basic steps for troubleshooting your turbine system. If the issue persists, please contact Flower Turbines support.



1. General Troubleshooting

- **Loose Connections:** Ensure all screws and bolts are securely tightened.
- **Misaligned Parts:** Re-align parts if they do not fit as expected.
- **Regular Checks:** Periodically check the assembly for any loose components or wear and tear.

2. Turbine Not Spinning

- **Possible Causes:**
 - Low wind speed below the cut-in threshold (0.7 m/s or 1.57 mph).
 - Debris or obstruction in or around the turbine.
 - Mechanical or electrical component failure.
- **Solutions:**
 - Verify wind speed in the area.
 - Inspect the turbine for debris or obstructions and clear them if present.
 - The turbine might not be performing well because of poor placement. Ideally turbines should be in an open area and exposed to the wind. If the turbine is on a rooftop, its blades should be as high above the railings as possible.
 - Check for loose or disconnected wires in the generator or charge controller.
 - To diagnose slow and hard spinning, start by disconnecting the electrical connection. An electrical components may be inhibiting the turbine, which could be due to various factors, such as a full battery, the charge controller or inverter settings, or a problem with the generator. Our generators are designed with low starting torque, making them an unlikely cause. The electronics may have their own manuals, which you should consult as needed.
 - If there is slow spinning, and the problem persists when disconnecting the electronics, the most common cause could be found along the central shaft. If the generator is tightly fixed on the bottom and not aligned in a continuous and straight vertical orientation with the rest of the shaft, there could be resistance. The coupling between the generator and the shaft could also slow down the turbine. The bearings are often a cause of slow turbine movement. Perhaps they are due for a greasing or the supplier produced faulty bearings. The seal around the bearings could be tight. If a new greasing doesn't solve the problem, then you should contact us with the problem and we will contact our engineers.

3. Low or No Power Output

- **Possible Causes:**
 - Low wind speeds or inconsistent gusts.
 - Faulty connections to the charge controller or inverter.
 - Malfunction in the generator or charge controller.
- **Solutions:**
 - Confirm wind conditions meet operational thresholds.



- Inspect all wiring connections for secure and proper setup.
- Verify that the charge controller and inverter are operational. Contact support for advanced troubleshooting.

4. Unusual Noise or Vibration

- **Possible Causes:**
 - Loose components (blades, shaft, or base).
 - Worn or damaged bearings.
 - Misalignment in the turbine assembly.
- **Solutions:**
 - Conduct a visual inspection for loose bolts or parts. Tighten if necessary.
 - Schedule maintenance to grease or replace worn bearings.
 - Ensure the turbine is securely mounted on a stable foundation.

5. Brake Not Engaging Automatically

- **Possible Causes:**
 - Programming issue in the charge controller.
 - Electrical connection failure in the braking system.
- **Solutions:**
 - Have a licensed electrician reset the charge controller.
 - Inspect connections to the brake system for faults or corrosion.

6. Controller or Indicator Light Malfunction

- **Possible Causes:**
 - Faulty controller unit.
 - Disconnected or damaged wiring.
- **Solutions:**
 - Verify power is reaching the controller.
 - Check for loose or damaged connections and secure them.
 - Replace the controller if needed and contact support for assistance.

7. Turbine Stopped Working After a Storm

- **Possible Causes:**
 - Excessive wind speeds caused damage to components.
 - Debris lodged in or around the turbine.
- **Solutions:**
 - Inspect the turbine for visible signs of damage and remove debris.
 - Verify the integrity of the blades, shaft, and base.
 - Contact a licensed professional or Flower Turbines support for repairs.



Liability Disclaimer

The manufacturer assumes no liability for any damages, injuries, or losses resulting from failure to comply with the specified assembly guidelines and safety standards. It is imperative that all assembly procedures be performed by certified professionals to uphold the product warranty, ensure safety, and preserve operational integrity. Unauthorized assembly or modification will void all warranties and protections provided by the manufacturer.

Warranty Information

1. **Warranty Statement for Flower Turbines:**

Flower Turbines warrants that its turbines are free from defects in materials and workmanship for a period of five (5) years applicable only to components made by Flower Turbines from the date of delivery to the original purchaser. Other components have their own warranty periods.

2. **Exclusions:**

This warranty does not cover damage caused by misuse, neglect, improper installation, accidents, acts of nature, or unauthorized modifications.

3. **Claim Process:**

To initiate a warranty claim, the original purchaser must submit a claim along with proof of purchase. Flower Turbines reserves the right to inspect the product and determine the validity of the claim.

4. **Limitation of Liability:**

Flower Turbines' liability under this warranty is limited to repairing or replacing the defective product at its discretion and excludes any incidental or consequential damages from product use.

5. **Extent of Warranty:**

This warranty is valid only for the original purchaser and is non-transferable.



Frequently Asked Questions

1. **Q: What are the dimensions of each turbine?**

A: When attached to the base, each Large Tulip is 19.685 ft (6 m) H x 7.87 ft (2.4 m) W.

2. **Q: How much does each turbine weigh?**

A: Each Large Tulip weighs 2204.62 lbs (1000 kg) when attached to the base.

3. **Q: What are the minimum and maximum wind speeds?**

A: The cut-in wind speed is 0.7m/s (1.57mph) and maximum survival wind speed is 54m/s (120.8mph). Our custom charge controllers include a built-in braking control for safety in high winds that may exceed the turbine's max wind speed ability.

4. **Q: What are the lowest and highest temperatures at which the turbines will operate?**

A: These turbines will operate at a range of 5°F to 122°F (-15°C to 50°C).

5. **Q: How long will my turbines last?**

A: These units are designed to operate for twenty (20) years, but we recommend checking them annually for any damage that could impact their lifespan.

6. **Q: When the unit has reached its lifetime max, are the blades recyclable?**

A: Yes! Our blades are made out of recyclable ABS thermoplastic.

Contact Information

For further assistance or inquiries, please contact us at:

Phone: +1 (806) 318-1116

Email: support.us@flowerturbines.com | support.eu@flowerturbines.com

Website: www.flowerturbines.com





Appendix

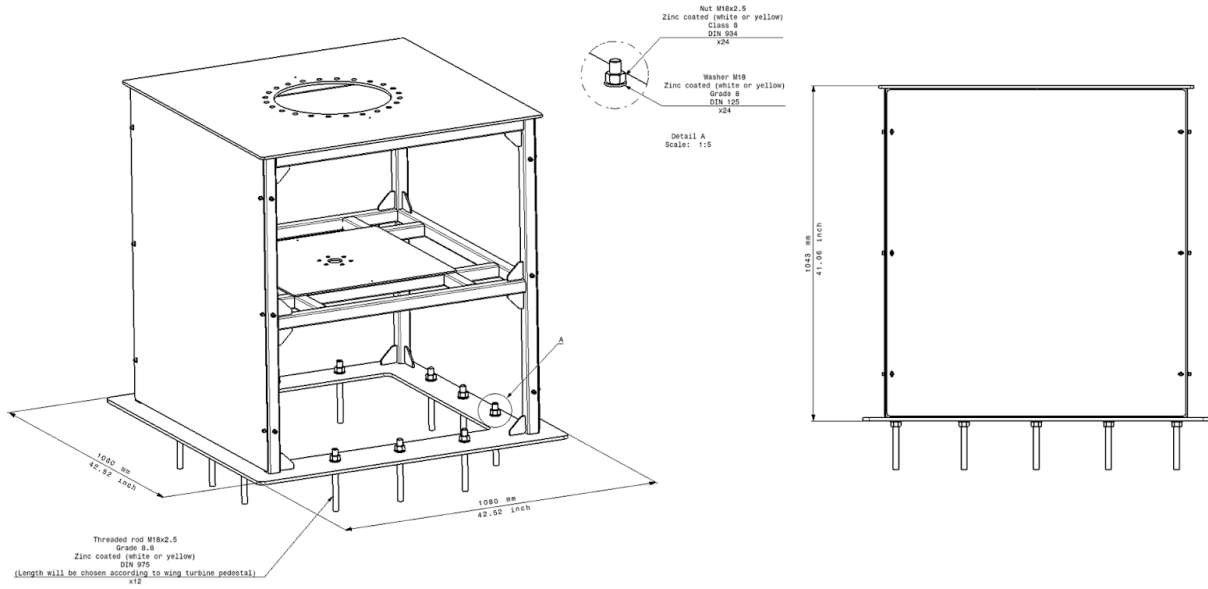

INTERNAL REVISIONS RECORD			
REV.	DATE	DESCRIPTION OF CHANGE	NAME
—	26/11/2023	NEW DRAWING	SJE/TB

REF.	X	Y	Diameter
A	-437.2	-225	20
B	-437.2	0	20
C	-437.2	225	20
D	-225	437.2	20
E	0	437.2	20
F	225	437.2	20
G	437.2	225	20
H	437.2	0	20
I	437.2	-225	20
J	225	-437.2	20
K	0	-437.2	20
L	-225	-437.2	20

Detail A
Scale: 1:1
x8

APPROVALS		TITLE:
NAME	DATE	
DRAWN DWA/S	26/11/2023	3case Plate
CHECKED KA 3	26/11/2023	
APPROVED MFG/APP.		

GENERAL NOTES:

- MATERIAL: 316L / INCONEL 625 / 10mm
- SPECIFICATIONS: INTERPRET THIS DRAWING I.A.W. ASME Y14.1; DIMENSIONS AND TOLERANCES ARE I.A.W. ASME Y14.5-14 SURFACE TEXTURE I.A.W. ASME B46.1 AND IN μm SURFACE ROUGHNESS 125μm
- FILES FOR MANUFACTURING: ALL DIMENSIONS ARE I.A.W. 3D MODEL FILE

PROJ. NO.: Flower Turbines 01

SHEET 1 OF 1